

Hopup Dimension Kit 03

Dimension Kit 03: HOP-DIM03-4X3FGE-S

Accessory Kit 03: HOP-DIM-03

Hopup™ Backwall Dimensions add style, flare and function to any 7½' or 10' wide Hopup straight display. Easily accessorize your Hopup with monitor mounts, counters, tables, and more messaging real estate. Purchase as a complete kit or as an accessory for your existing straight Hopup. Dimensional elements can be placed in the middle, left or right sides of the display.



Dimension Kit 03:
HOP-DIM03-4X3FGE-S









Accessory Kit 03:
HOP-DIM-03

We are continually improving and modifying our product range and reserve the right to vary the specifications without prior notice. All dimensions and weights quoted are approximate and we accept no responsibility for variance. E&OE. See Graphic Templates for graphic bleed specifications.

features and benefits:

- **Dimension Kit 03 includes:** 10' wide full height straight backwall, accessory counter with monitor mount, fabric printed graphic and literature holder and two Lumina 200 spot lights
- Counter top holds max weight of 35 lbs.
- **Accessory Kit 03 includes:** stand-off counter with fabric printed graphic, literature holder and monitor mount
- Lifetime limited hardware warranty against manufacturer defects

dimensions:

Hardware	Graphic
<p>Dimension Kit 03 assembled unit: 118.75" w x 91" h x 36.375" d 3016mm(w) x 2311mm(h) x 924mm(d)</p> <p>Stand-off counter: 34" w x 35" h x 11.25" d 864mm(w) x 889mm(h) x 286mm(d)</p> <p>Dimension Kit 03 Weight: 68 lbs / 31 kgs</p> <p>Accessory Kit 03 Weight: 39 lbs / 18 kgs</p> <p>Carry bag: 2 lbs / 1 kgs</p>	<p>Refer to related graphic template for more information.</p> <p>Visit: www.exhibitors-handbook.com/graphic-templates</p>
<h3>additional information:</h3> <p>Graphic material: Dye-sublimation zipper pillowcase fabric</p> <p>Counter holds max weight of 35 lbs</p> <p>Monitor mount supports 32"-55" LCD's, max weight = 80 lbs (monitor not included)</p> <p>Accessory Kit 03 does not include backwall frame or lights</p> <p>When included in a larger kit, a different packaging solution will be listed to accommodate all contents of the kit. Individual packaging no longer provided.</p>	
<h3>Shipping</h3> <p>Shipping dimensions: Dimension Kit 03 (two boxes): 36" l x 15" h x 13" d 914mm(l) x 381mm(h) x 330mm(d)</p> <p>Accessory Kit 03 (one box): 40" l x 18" h x 7" d 1016mm(l) x 457mm(h) x 178mm(d)</p> <p>Shipping weight: Dimension Kit 03 (two boxes): 70 lbs / 32 kgs OCP2 upgrade option: 110 lbs / 50 kgs</p> <p>Accessory Kit 03 (one box): 41 lbs / 19 kgs OCP2 upgrade option: 76 lbs / 35 kgs</p>	
<p>Tabletop Colors:</p> <div style="display: flex; justify-content: space-around; align-items: center;"> <div style="text-align: center;">  silver </div> <div style="text-align: center;">  black </div> <div style="text-align: center;">  mahogany </div> <div style="text-align: center;">  natural </div> </div> <p>2 person assembly recommended:</p> <div style="display: flex; justify-content: space-around;">   </div>	

SET-UP: STEP 1
GRAPHIC COMES ATTACHED

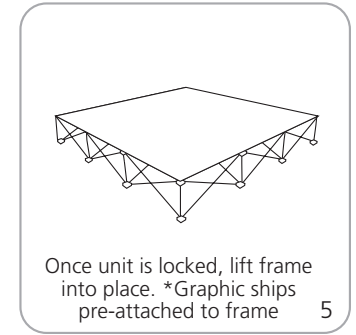
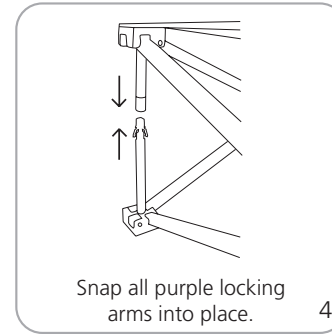
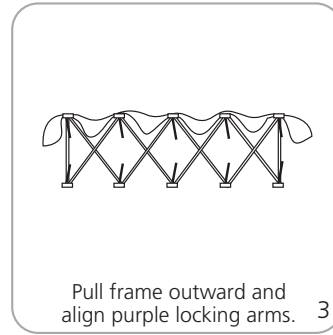
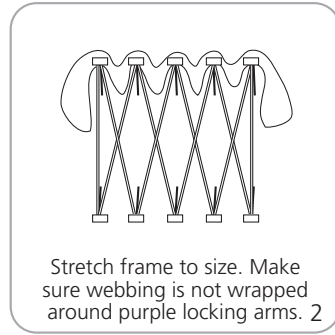
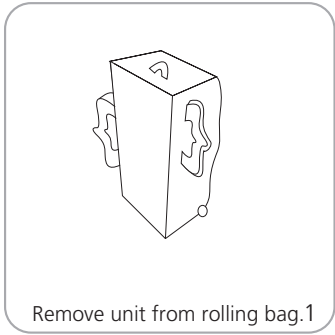

TO ATTACH END CAPS

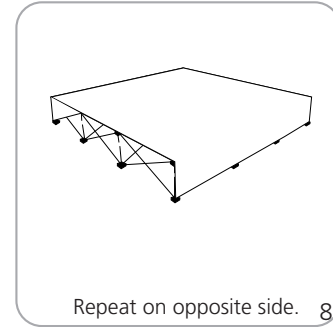
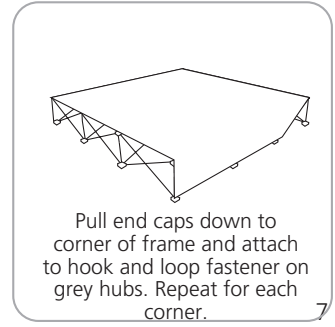

ATTACH STABILIZER FEET TO FRAMES 3 QUADS HIGH

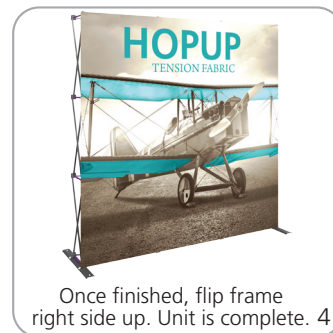
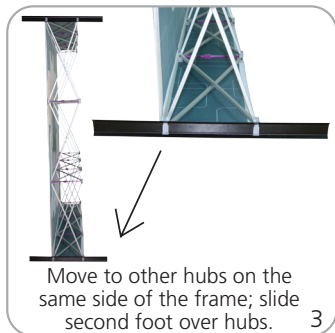
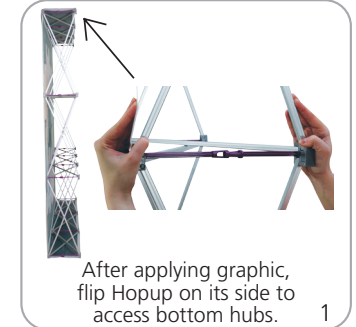

TO ATTACH LIGHTS

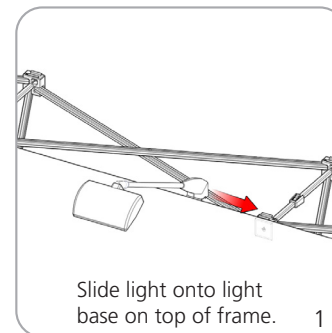

TO COLLAPSE

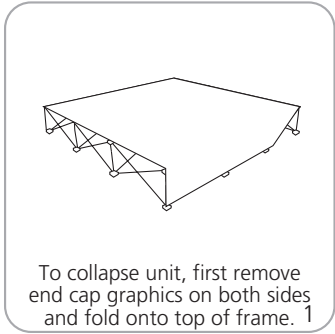

To collapse unit, first remove end cap graphics on both sides and fold onto top of frame. 1

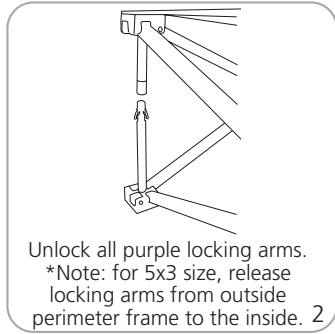

Unlock all purple locking arms. *Note: for 5x3 size, release locking arms from outside perimeter frame to the inside. 2

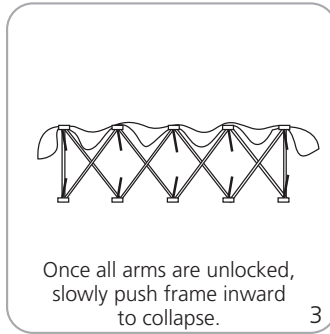

Once all arms are unlocked, slowly push frame inward to collapse. 3

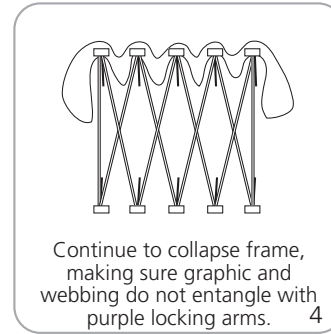

Continue to collapse frame, making sure graphic and webbing do not entangle with purple locking arms. 4



Store unit into rolling bag. Be sure bag straps do not wrap around purple locking arms. 5

To ensure quality, please note:



If the webbing is wrapped around the purple locking arm, the arm can snap off when opening the unit.

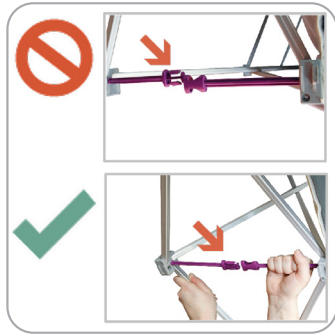

When setting up, ensure that the arms are aligned. If not, the arms will snap when pressure is applied.



When packing unit in the bag, ensure that the strap is not partially wrapped around an arm. If it is, the arm will snap when pulled out of the bag.

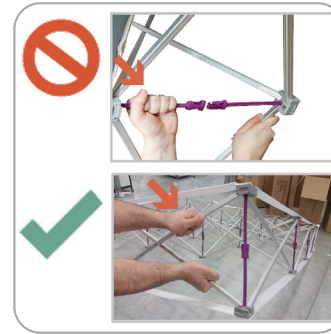

Do not use the purple locking arm to lift unit. ALWAYS lift by the frame.

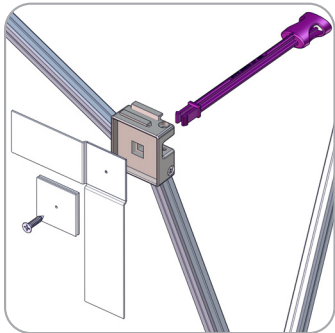

To detach the female arm, remove the screw, steel plate and hook and loop fastener webbing. Pull the arm off the hub.

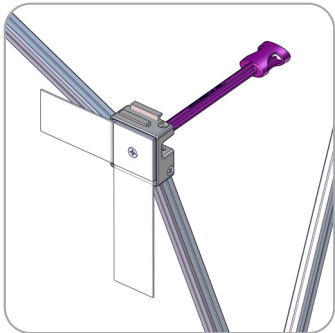

Attach the female arm by popping it into the hub. Fasten the screw through the steel plate hole and the hook and loop fastener webbing tapping into the female arm.

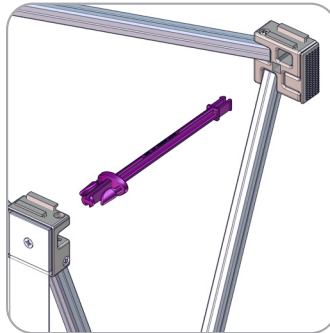

To detach the male arm, pull the arm off the hub.

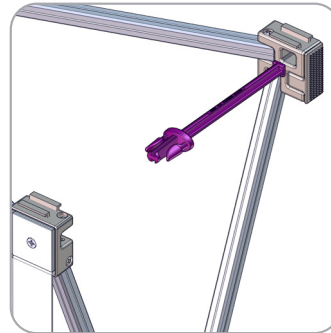

Simply pop in the male arm into the hub.

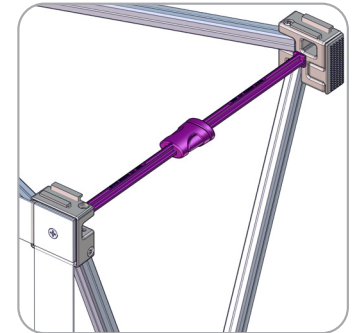

Both arms should align to snap lock together.

STEP 2: ATTACH STABILIZER FEET

Flip Hopup on side to access bottom hubs. Start with the largest end of the opening and slide stabilizer foot over both hubs. Feet will fit snugly. Push down on the tension clip to insert the hub into the stabilizing foot. Stabilizing feet will securely snap lock onto hubs. To release foot press tab and slide. Attach the large stabilizing feet on bottom. Then, attach the three smaller stabilizing feet (labelled call outs in the image at the right).

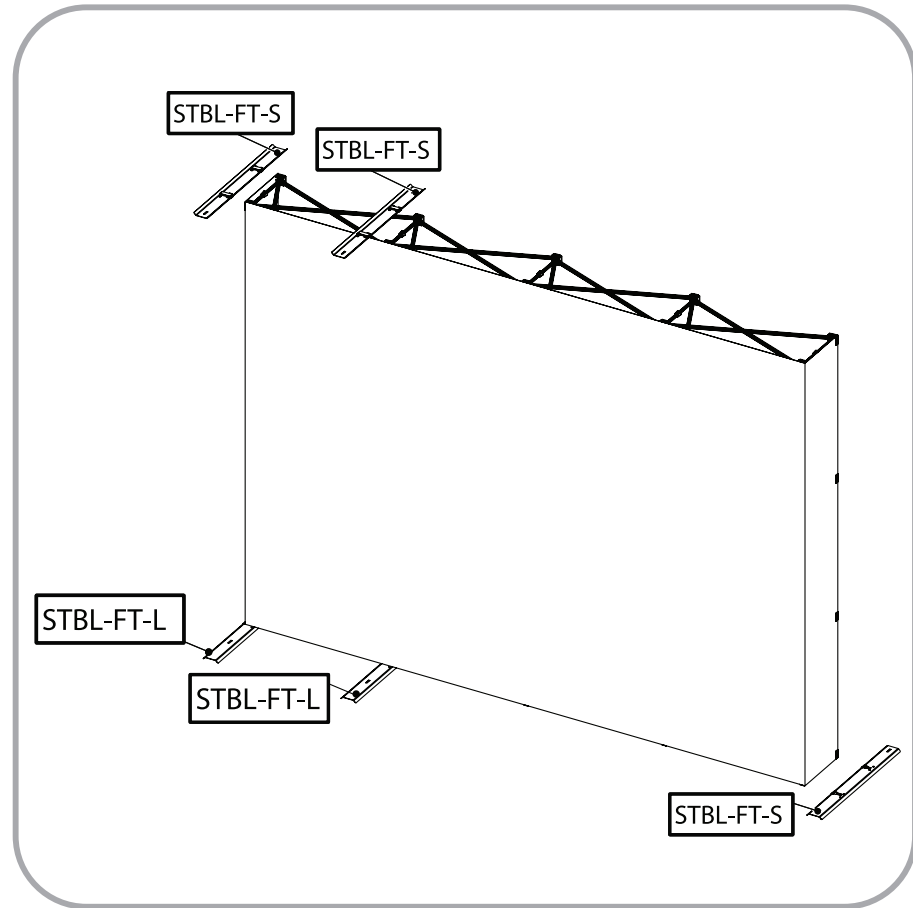
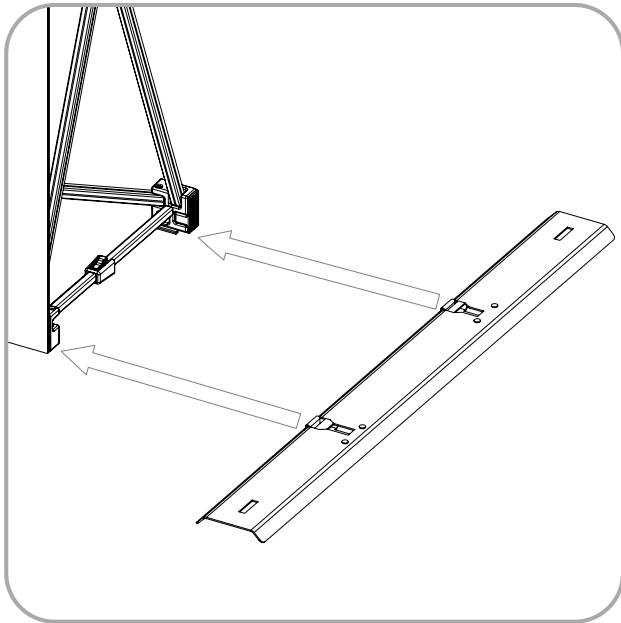
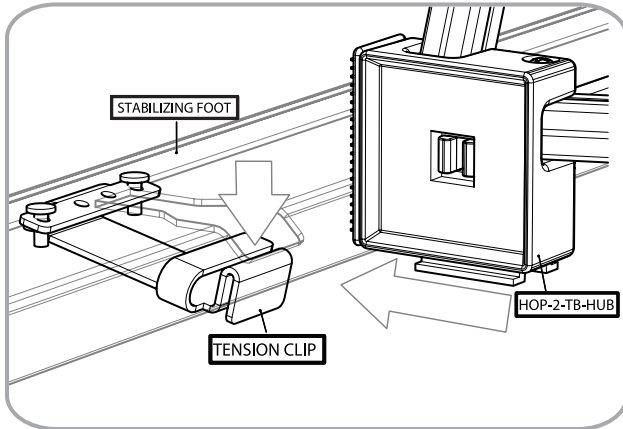

STEP 3: ASSEMBLE COUNTER FRAME

Insert IB2 into hole locations on PS2-756-S1-S1-IN. With Allen Key tool, turn one quarter turn to lock into place. Slide FC-726 into channel PH-726-S-S-IN. Then lock PH-726-S-S-IN into the internal channels on the PS2-756-S1-S1-IN.

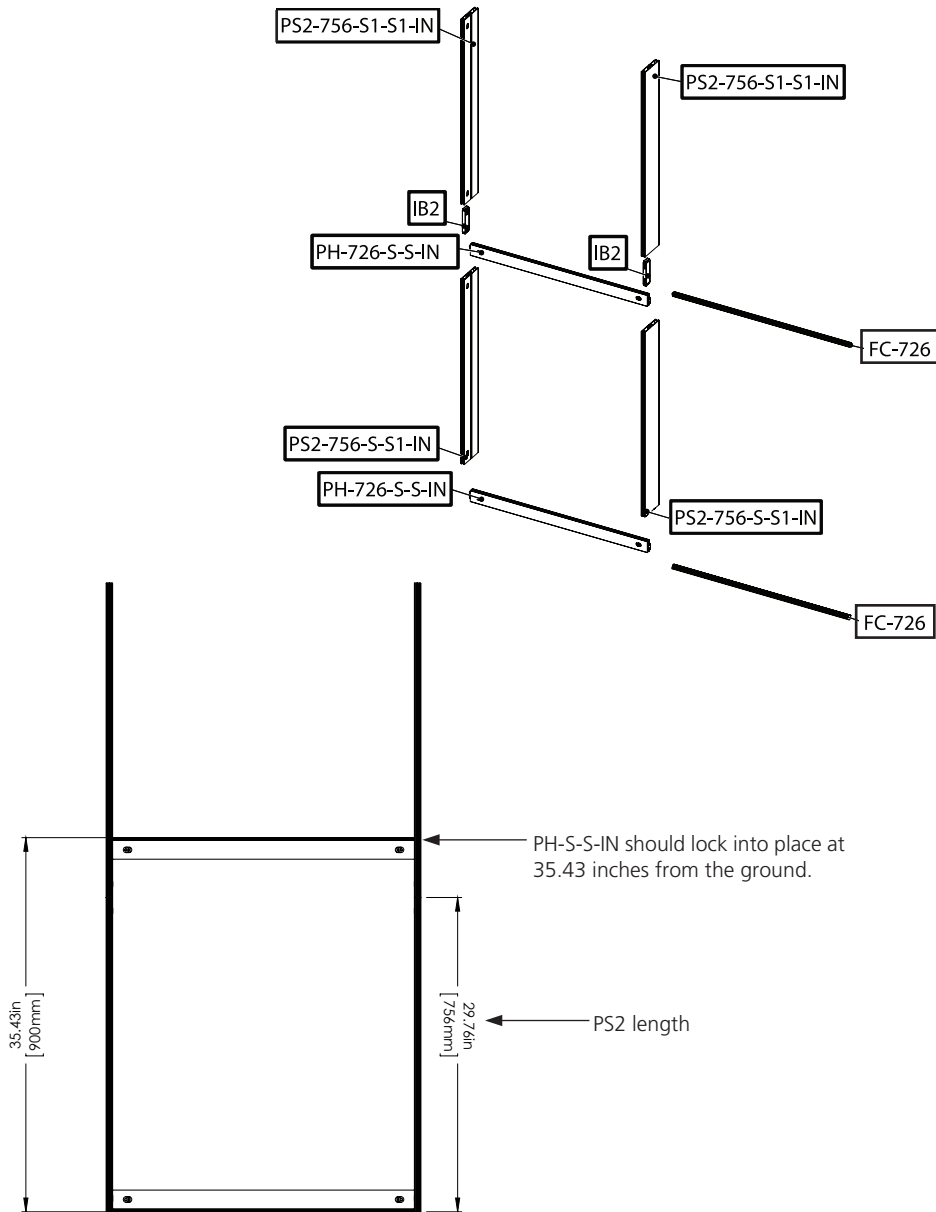

***Note:** All PS2-756-S1-S1-IN pieces are the same length.

Lock PH-90-L onto the rear channel of the PS2-756-S1-S1-IN at location shown in image. With Allen Key tool, turn only one quarter turn to lock into place. Silicon graphic edge (DS-FCE-2-G-DIM) will push into the channel on the FC-726.

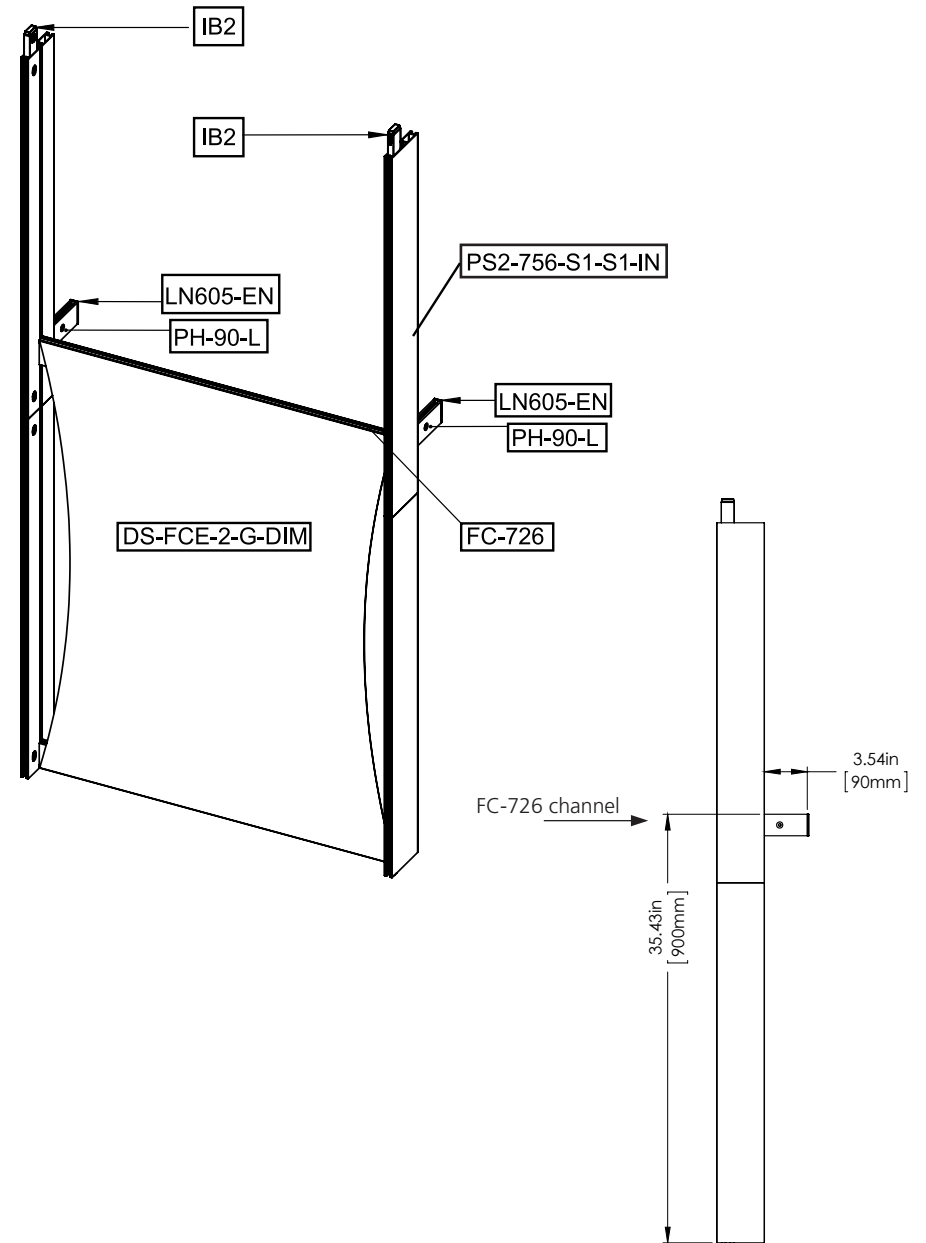

STEP 3 CONTINUED:

Assemble top of frame by inserting IB2 into hole locations on PS2-756-S1-S1-IN. With Allen Key tool, turn one quarter turn to lock into place.

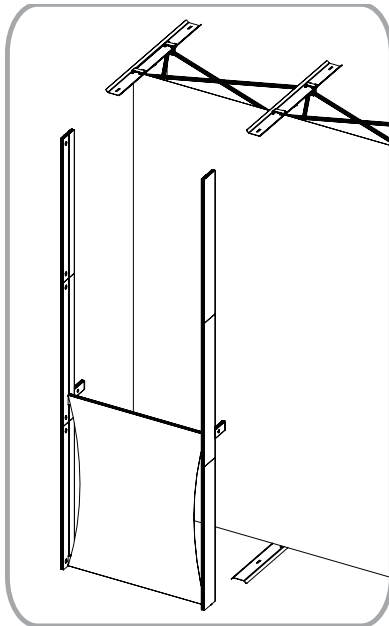
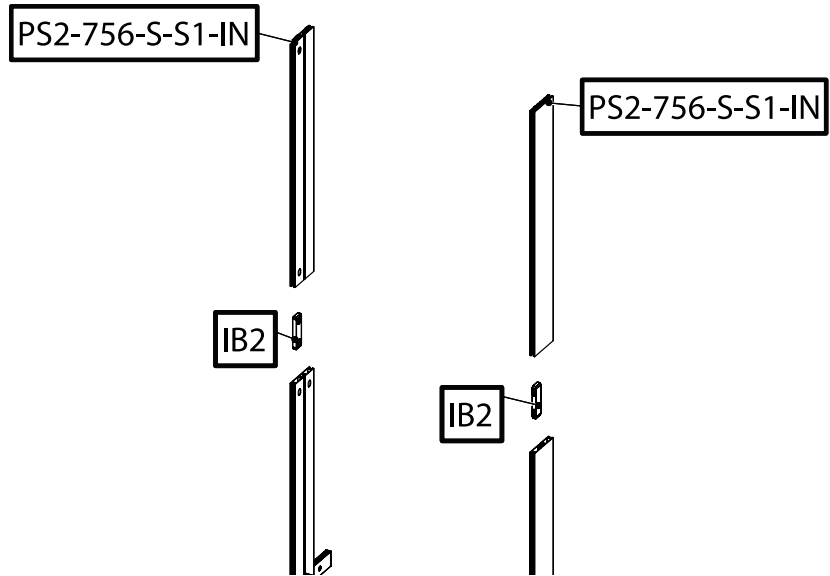

Lock extrusion frame onto top and bottom stabilizing feet, using fixed cam lock. With Allen Key tool, turn one quarter turn to lock into place.

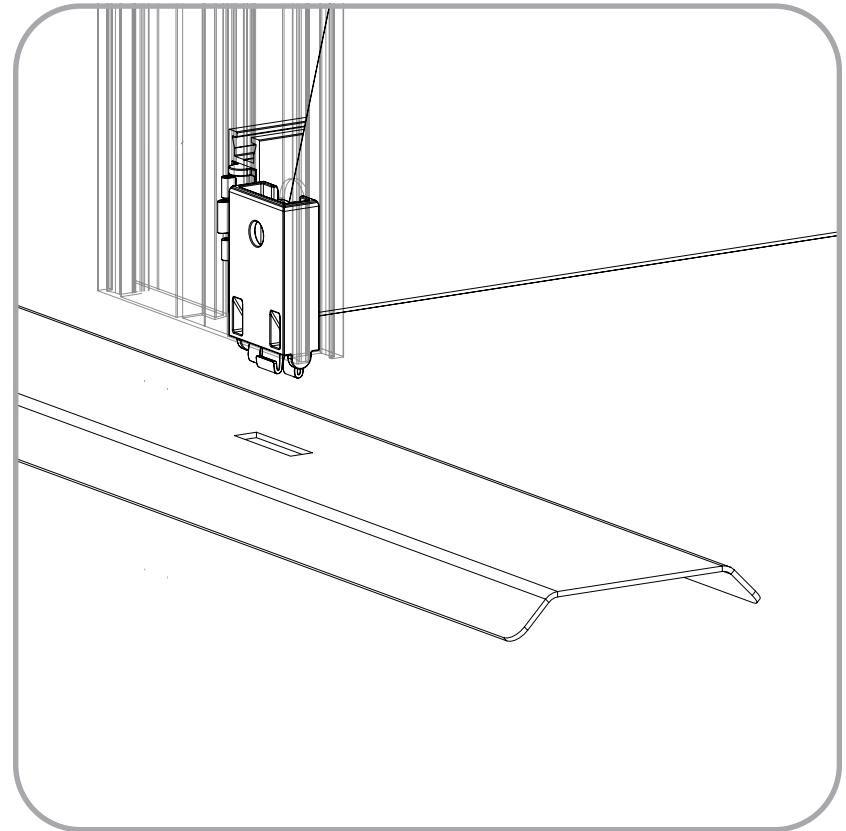

STEP 4: ATTACH ACCESSORIES

Assemble EXT-M-MB monitor mount, then attach to frame. PS2-726-S-S-IN with monitor mount attachment should lock into place at 16.85 inches from top of unit. With Allen Key tool, turn one quarter turn to lock into place. See supplemental sheet for further instructions.

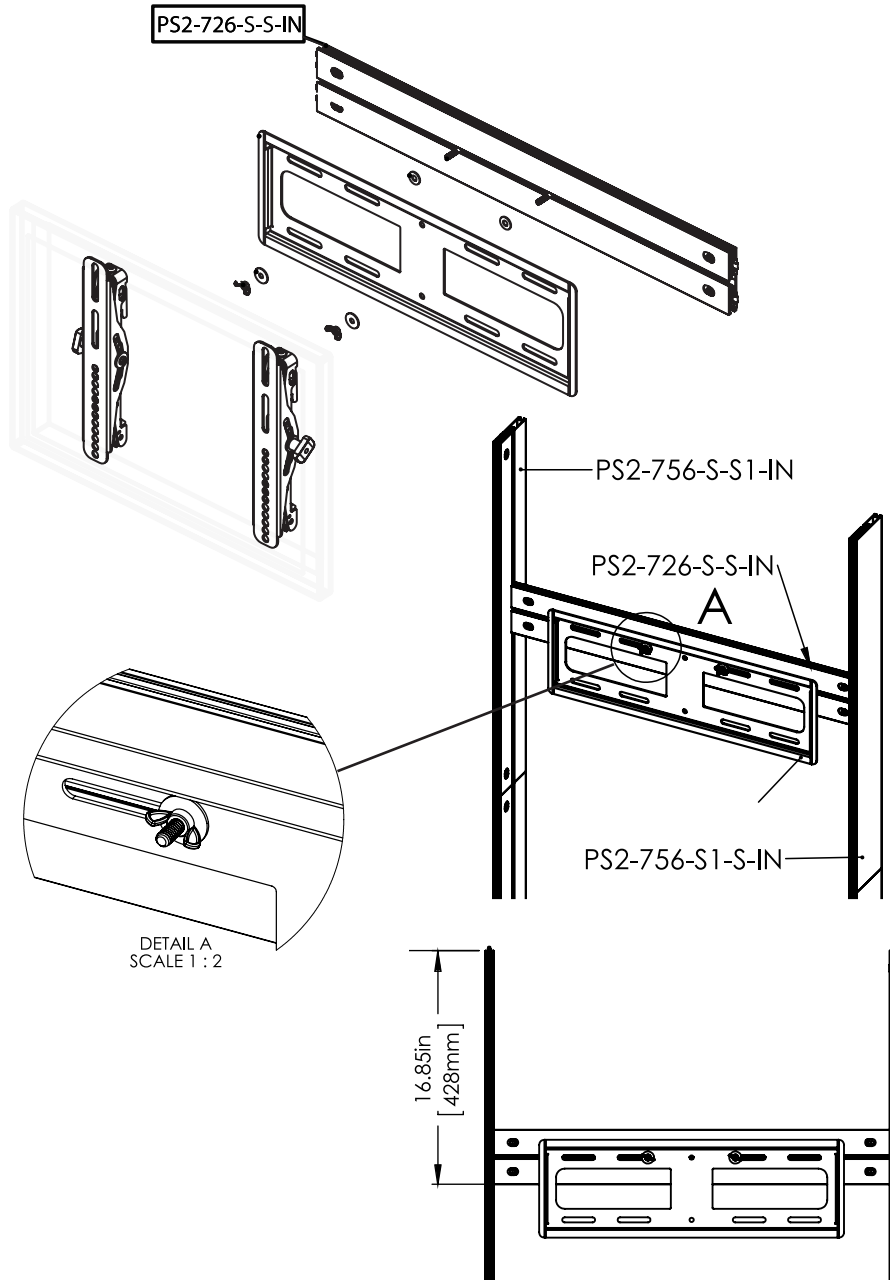

Attach shelf to frame. Lay shelf flat onto counter frame.

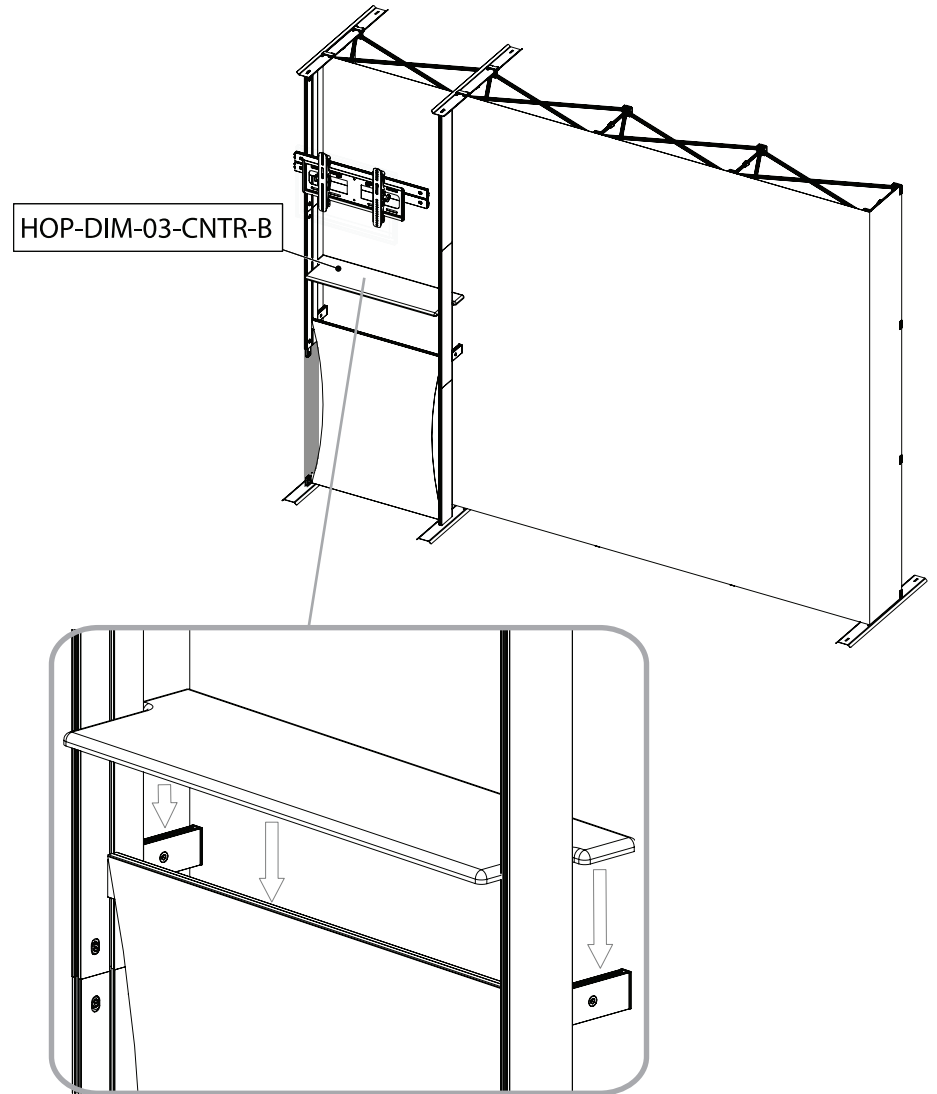

STEP 4 CONTINUED:

Attach the literature pocket to the extrusion.

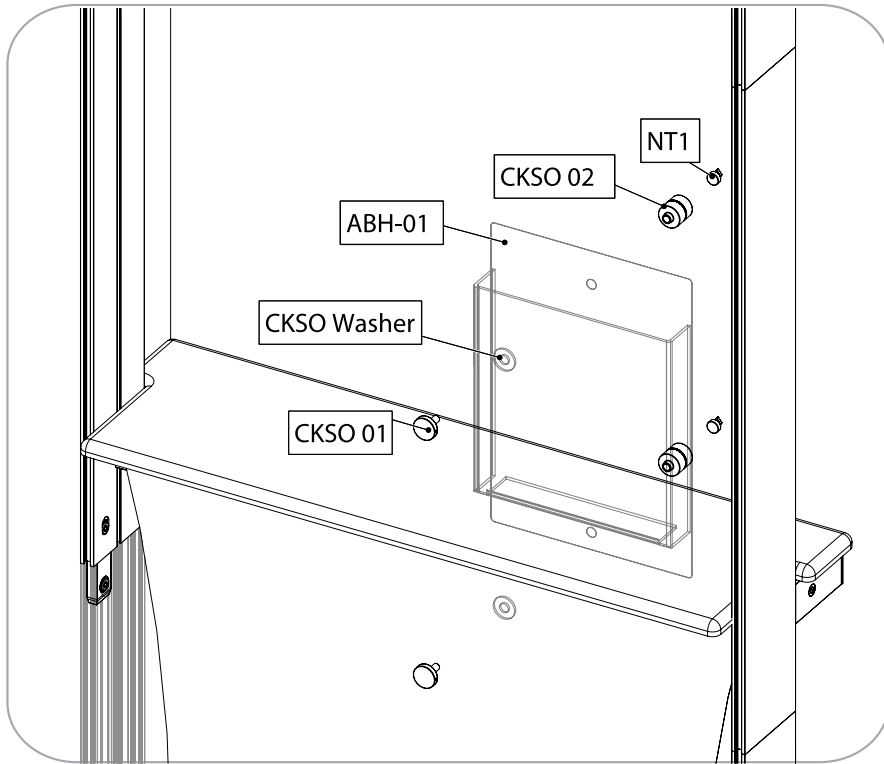

Attach lights by sliding light onto the dovetail on the hub at the top of the frame.

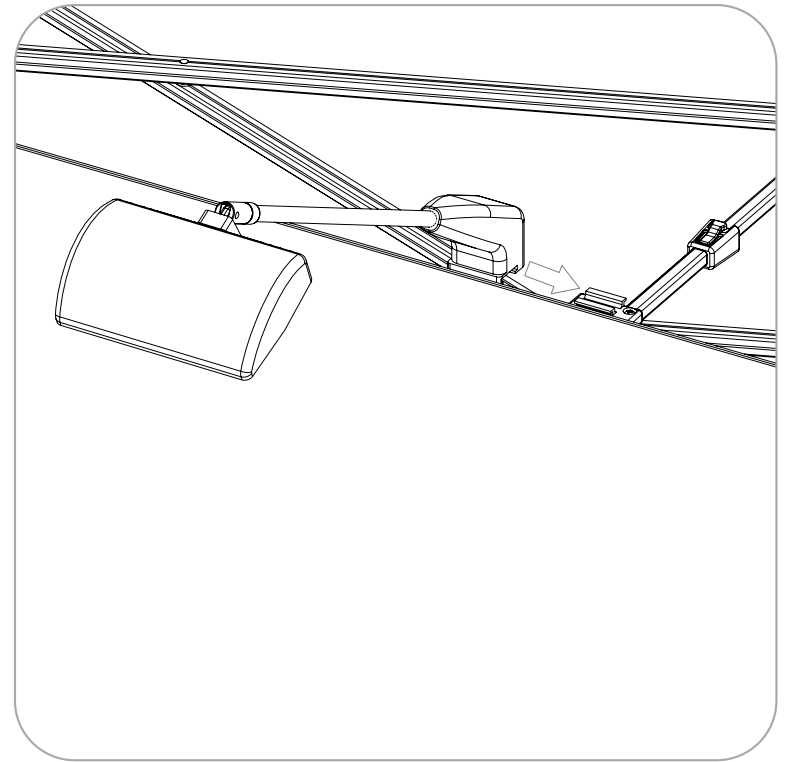

HOPUP GRAPHIC ATTACHMENT:

Graphic comes pre-attached to frame. Graphic attaches to the frame with hook and loop fastener. To re-attach start in one corner and move on to the next. Graphic application is then complete.

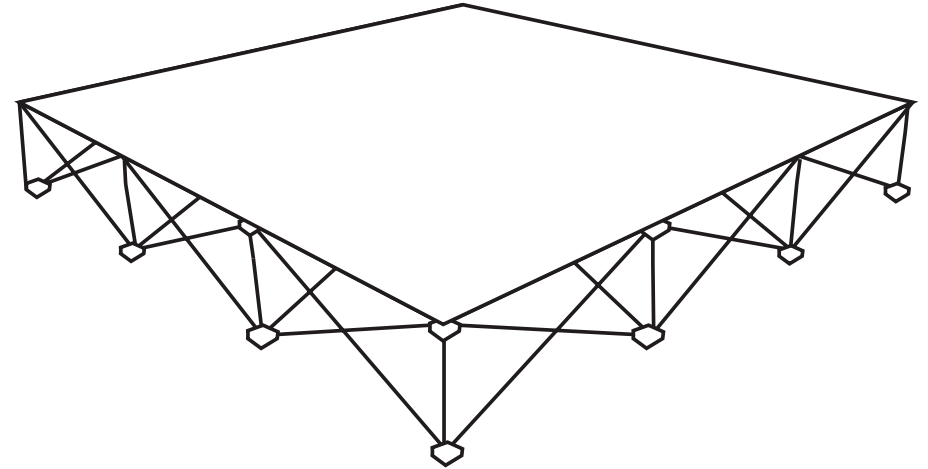
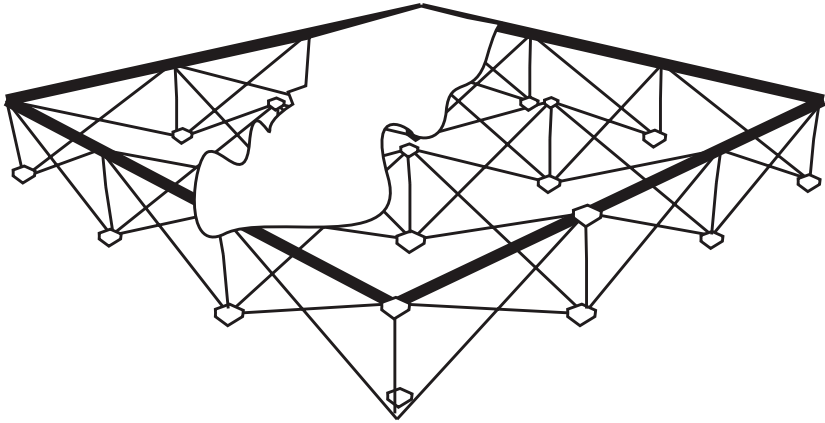

to ensure quality, please note:



If the webbing is wrapped around the purple locking arm, the arm can snap off when opening the unit.



When setting up, ensure that the arms are aligned. If not, the arms will snap when pressure is applied.



When packing unit in the bag, ensure that the strap is not partially wrapped around an arm. If it is, the arm will snap when pulled out of the bag.



When placing in a non-roller bag, ensure that arms are not outside of the bag.



Do not use the purple locking arm to lift unit. ALWAYS lift by the frame.

Monitor Bracket Instructions

Extrusion Channel Applications



EXT-SM-MB

Sizes: 17" - 37"

Max weight varies per application

Assembled unit:

9" w x 16" h x 1.4" d
230mm (w) x 410mm (h) x 35mm (d)

Shipping dimensions:

14" l x 6" h x 4" d
356mm (l) x 152mm (h) x 102mm (d)

Approximate total shipping weight:

6 lbs / 2.7 kgs

VESA:

75 x 75 - 200 x 200mm



EXT-M-MB

Sizes: 32" - 55"

Max weight varies per application

Assembled unit:

16" w x 16" h x 1.4" d
410mm (w) x 410mm (h) x 35mm (d)

Shipping dimensions:

24" l x 4" h x 4" d
610mm (l) x 102mm (h) x 102mm (d)

Approximate total shipping weight:

7 lbs / 3.2 kgs

VESA:

100 x 100 - 400 x 400mm



EXT-LG-MB

Sizes: 40" - 65"

Max weight varies per application

Assembled unit:

24" w x 16" h x 1.4" d
610mm (w) x 410mm (h) x 35mm (d)

Shipping dimensions:

28" l x 6" h x 6" d
711mm (l) x 152mm (h) x 152mm (d)

Approximate total shipping weight:

8 lbs. / 3.6 kgs

VESA:

100 x 100 - 600 x 400mm

Included hardware:

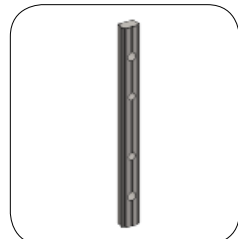

LN-100

x2



M5 x 10

LN-LCD-SCW x2



1/4"-20 x 1"

BOLT-1 x2

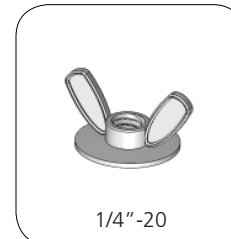

1/4"-20

Flange Wingnut x2

EXTRUSION CONNECTION

Channel Connection A

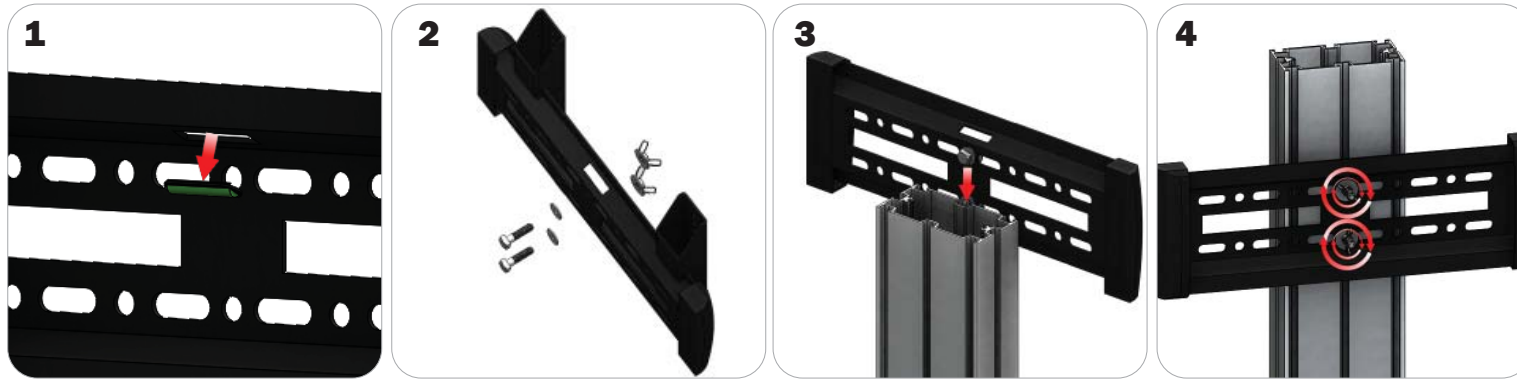

Locate all components needed to assemble the monitor mount with the channel connection A method. You will need (1) monitor bracket, (2) square head bolts, (2) washers, and (2) wingnuts.

Step 1: Apply pressure to the rear side of the leveling gauge clipped into the monitor mount to remove it. **Step 2:** Insert the provided bolts through the washers and center top and bottom holes of the monitor mount. Loosely thread your wingnuts onto the end of the bolts. **Step 3:** Slide the bolt heads down the extrusion channel.

Step 4: Tighten your wingnuts to lock the monitor bracket in place. **Step 5:** Reference the included manufacturer monitor mount instructions for fastening your monitor to the bracket.

Channel Connection B

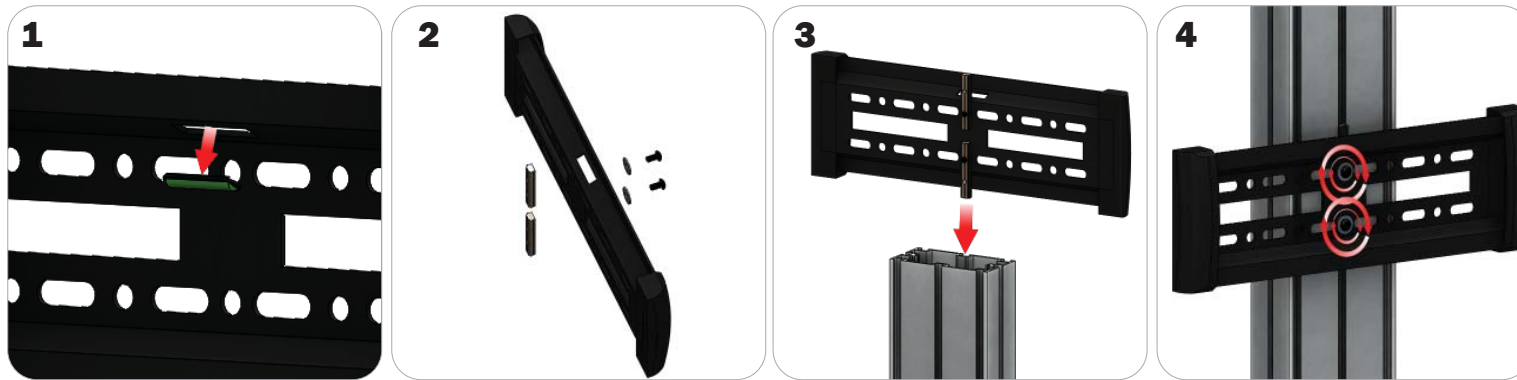

Locate all components needed to assemble the monitor mount with the channel connection B method. You will need (1) monitor bracket, (2) LN-LCD-SCW, (2) LN-100, and (2) washers.

Step 1: Apply pressure to the rear side of the leveling gauge clipped into the monitor mount to remove it. **Step 2:** Loosely thread the LN-LCD-SCW screws through the washers, the center top and bottom holes of the monitor bracket, and through the LN-50 holes. **Step 3:** Slide the LN-100s down the extrusion channel. **Step 4:** Tighten your LN-LCD-SCW to lock the monitor bracket in place.

Step 5: Reference the included manufacturer monitor mount instructions for fastening your monitor to the bracket.

TRI-30MM Channel Tube Connection

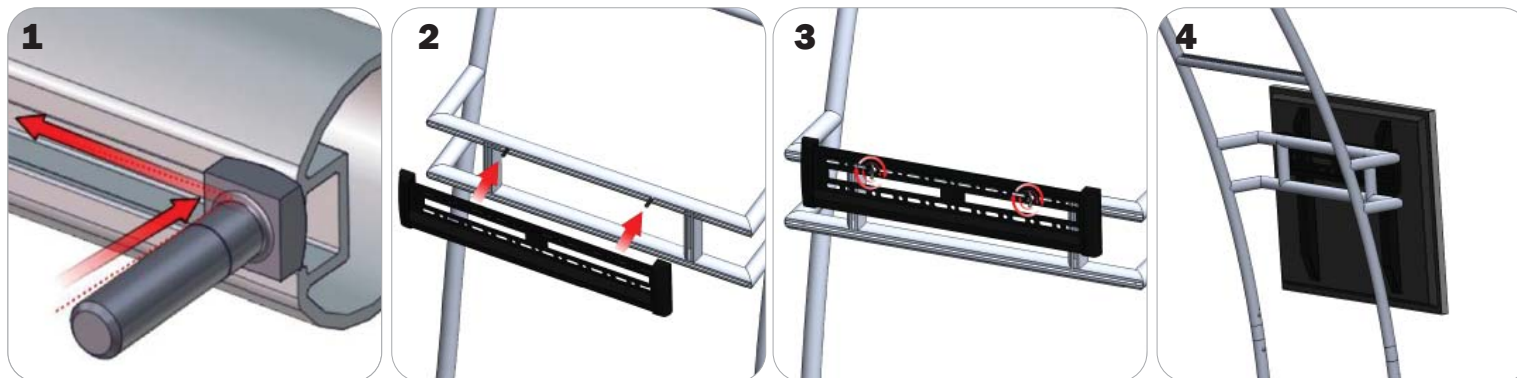

Locate all components needed to assemble the monitor mount with the TRI-30MM Channel Tube Connection method. You will need (1) monitor bracket, (2) Square Bolts, and (2) Wingnuts.

Step 1: Slip the head of the square bolts into the extrusion channel of the tube. **Step 2:** Apply your monitor bracket to the protruding square bolts. **Step 3:** Lock your monitor bracket to the square bolts using the provided wingnuts. **Step 4:** Reference the included manufacturer monitor mount instructions for fastening your monitor to the bracket.