

# TRI-1203

## SET UP INSTRUCTIONS:

1. CONNECT BOTTOM AND TOP TUBES FOLLOWING THE LABELS
2. CONNECT SIDE TUBES
3. CLEAN THE FRAME AND PLACE THEM ON CLEAN PLACE
4. CAREFULLY REMOVE FABRIC COVER FROM BAG
5. PLACE COVER AROUND THE BOTTOM OF THE FRAME
6. PULL COVER CAREFULLY UP TO THE TOP
7. CLOSE ALL ZIPPERS
8. ADJUST FABRIC AROUND THE FRAME
9. CONNECT CABLE HARNESS TO THE EYEBOLTS
10. COMPLETELY TIGHTEN THREADED CONNECTORS

## BREAK DOWN INSTRUCTIONS:

REVERSE SET-UP STEPS TO BREAKDOWN FRAME

## FABRIC CARE INSTRUCTIONS:

1. UNZIP COVER ZIPPERS
2. CAREFULLY REMOVE FABRIC COVER
3. CLOSE ALL ZIPPERS
4. FOLD OR ROLL NEATLY
5. PLACE FABRIC IN COVER BAG

TOTAL WEIGHT: 44.0 (lbs)

MAX SIZE: 44.8 (in)

HARDWARE: 26.4 (lbs)

GRAPHIC: 15.0 (lbs)

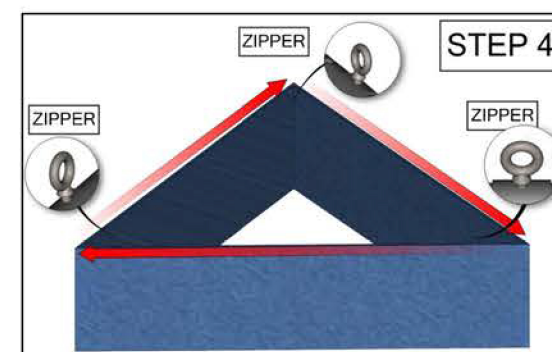
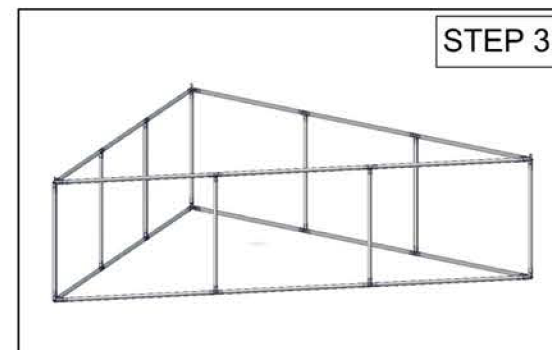
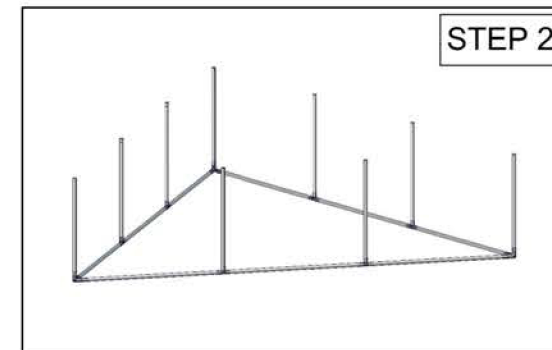
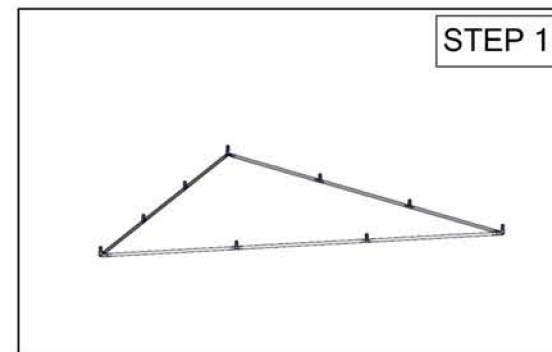
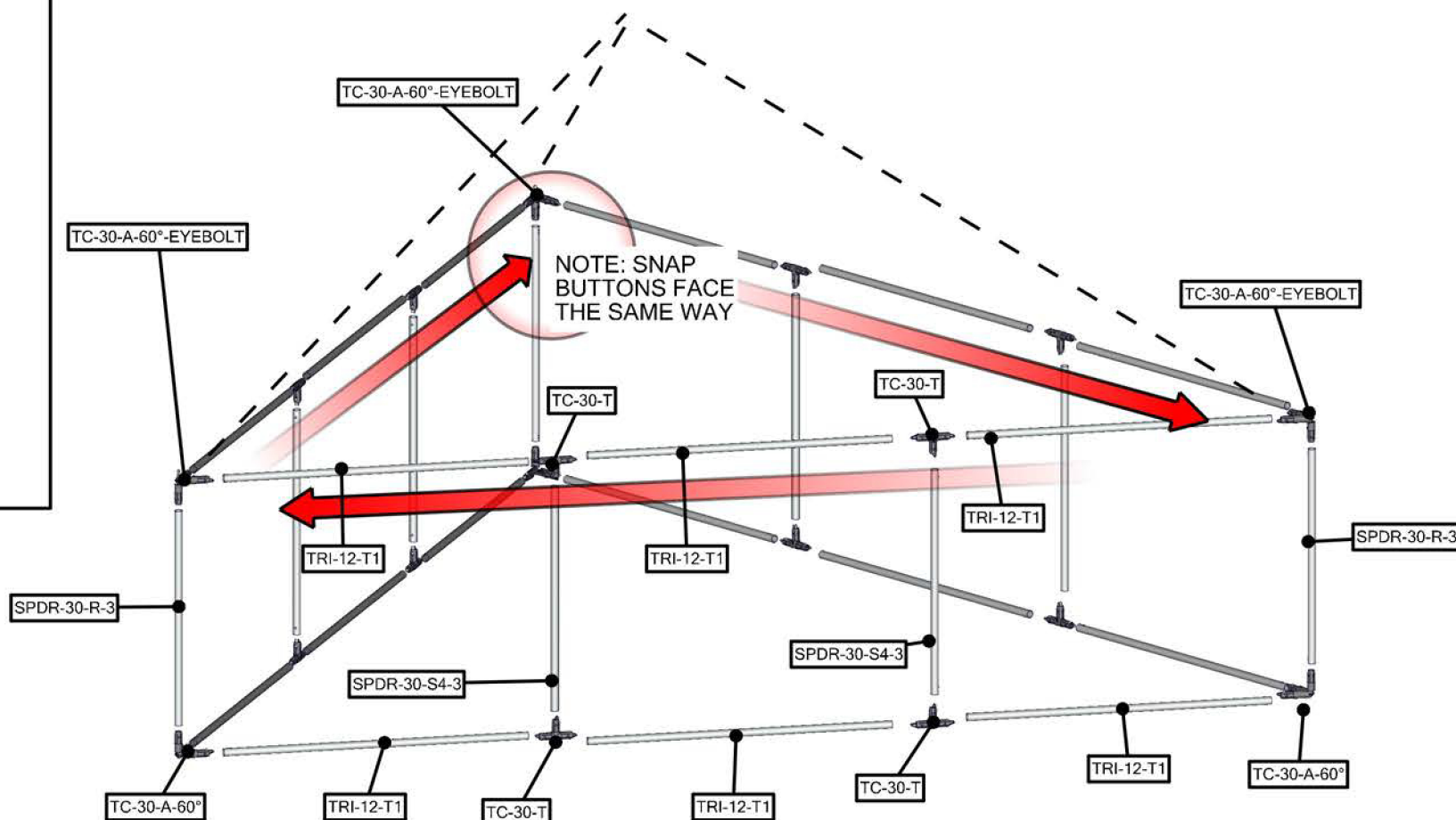

QTY	CODE	DESCRIPTION
3	SPDR-30-R-3	30MM STRAIGHT SPREADER FOR CORNERS OF 3' STRUCTURES USING RIVETS
6	SPDR-30-S4-3	30MM STRAIGHT SPREADER FOR CORNERS TO TC-30-90T JUNCTIONS OF 3' STRUCTURES USING RIVETS
3	TC-30-A-60°	TC-30-A ASSEMBLED at 60°
3	TC-30-A-60°-EYEBOLT	TC-30-A ASSEMBLED at 60° WITH 1/4-20 EYE BOLT
12	TC-30-T	T JUNCTION FOR 30MM TUBING
18	TRI-12-T1	TUBE 1 FOR 12 TRIANGLE HANGING FABRIC STRUCTURE

